

# DIESELMANOR

## INSTALLATION INSTRUCTIONS

### Cooler Line Manifold for 1/2" OD Tube Part #: FTG-MFD50

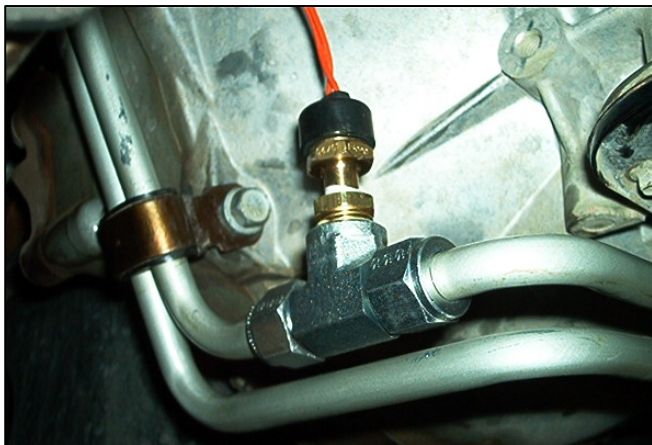

1) Identify the Cooler Feed line.

2) You will be cutting exactly 1.00" out of this line with a pipe cutter. It will be helpful to remove the retaining bracket prior to using the tubing cutter. You may also want to completely remove the cooler line and do this on a work bench.

3) Locate a point between the bends in the cooler line and measure exactly 1.00" and mark it. With a straight edge, draw a 5-6" line on the tubing, centered over your 1" marks. This line will extend beyond each end of the manifold and help you re-align both cut pieces later.

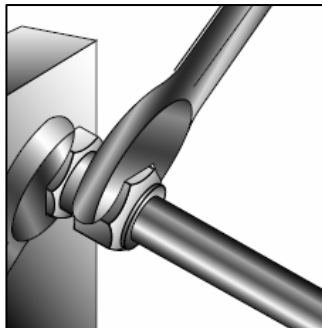
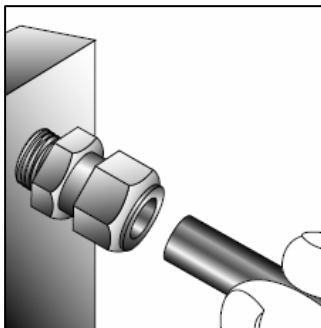

4) Using a pipe (tubing) cutter, cut this portion of the line out. Chamfer both cut ends with a deburring tool.

5) Install the Manifold by inserting both cut ends of the tube into the openings.

6) Tighten each nut finger tight. Then tighten nut an additional 1-1/4 turns with a 7/8" wrench. Hold manifold body with a second wrench to prevent it from turning. It is helpful to mark the nut to facilitate counting the number of turns.

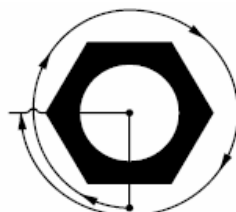
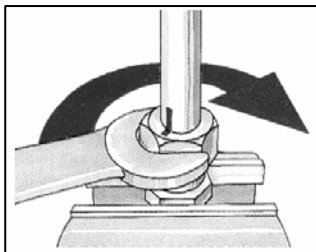

1-1/4 Turns from  
Finger Tight



DieselManor, Inc.  
61 Peppermint St.  
Goffstown, NH 03045

www.dieselmanor.com info@dieselmanor.com Phone 603-497-2281